

2024 Promotion

Free drill body with insert purchase, details below

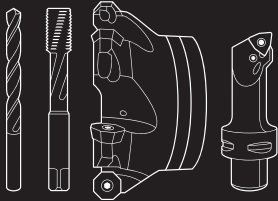

Strong performance
with four cutting edges

D3120

PROGRAM BENEFITS

- Same insert size for center and periphery insert pocket (operator convenience)
- Maximum process reliability due to easy chip removal
- Best protection against friction due to hardened and polished surfaces
- High stability in all working conditions
- Low cutting tool material costs due to four cutting edges
- Measuring collar for easy drill identification (even when assembled)

Powered by
Tiger-tec®Silver
Tiger-tec®Gold

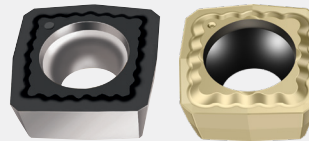

A57 – The strong geometry

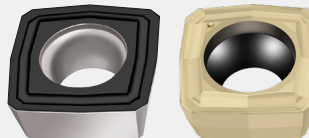

E57 – The universal geometry

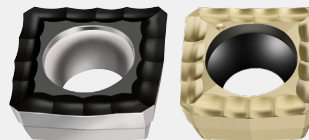

E67 – The sharp geometry



Promotion Details

Buy any 30 inserts of P284* style and get the tool for free. Promotion runs from September 15th, 2024 to December 27th, 2024.







Use promo code **DRILLING2024**

Designation key for Walter drilling tools with indexable inserts





D	3	1	20	—	03	—	16.00	F25	—	P21
1	2	3	4	5	6	7	8	9		

1	2	3	4	5	6	7	8	9
Tool group	Generation	Tool type	Tool type	Unit of Measure	Drilling depth	Cutting diameter/ clamping diameter	Shank type and size, cylindrical	Insert size
D Drilling		1 Cylindrical drill 2 Chamfer drills	20 Indexable insert drill with square indexable insert 40 Indexable insert drill with P600x exchangeable insert	— Metric . Inch	02 $2 \times D_c$ 03 $3 \times D_c$ 04 $4 \times D_c$		F25 25 mm F32 32 mm F40 40 mm F26 1.000 inch F31 1.250 inch F38 1.500 inch	 P21 P284 Size 1 P25 P284 Size 7
							A=Cylindrical shank	
							F=Cylindrical shank with flat	
							* shank sizes shown for example only	

Product range overview of indexable insert drills

			
Drilling depth	$2 \times D_c$	$3 \times D_c$	$4 \times D_c$
Designation	D3120	D3120	D3120
Dia. range [mm]	16–42	16–58	16–42
Dia. range [in]	–	0.750-1.500	0.750-1.500
			

Indexable inserts

Designation	Insert sizes	P		M			K			N		S			Stability of machine, workpiece and clamping arrangement
		HC	HC	HC	HC	HC	HC	HC	HC	HW	HW	HC	HC		
	P2840S-.N-A57	1-7	⊗	⊗	⊗	⊗	⊗	⊗	⊗	⊗	⊗	⊗	⊗	⊗	 Very good  Good  Moderate
	P2840S-.N-E67	1-7	⊗	⊗	⊗	⊗	⊗	⊗	⊗	⊗	⊗	⊗	⊗	⊗	
	P2841S-.N-A57	1-7	⊗	⊗	⊗	⊗	⊗	⊗	⊗	⊗	⊗	⊗	⊗	⊗	
	P2841S-.N-E57	1-7	⊗	⊗	⊗	⊗	⊗	⊗	⊗	⊗	⊗	⊗	⊗	⊗	
	P2841S-.N-E67	1-7	⊗	⊗	⊗	⊗	⊗	⊗	⊗	⊗	⊗	⊗	⊗	⊗	

P2840. = Ground Insert
P2841. = Pressed Insert

A57, E57, E67 are different chip breaker geometries.

Some geometry and grade combinations not available in all sizes

HC = Coated carbide
HW = Uncoated carbide

Walter Technical
Compendium



Follow link for technical
information on grades
and chip breaker
geometries